

STAINLESS STEEL SWING CHECK F/E - 150# & 300#

LEHRY MAKE CF8 / CF8M / CF3M Swing Check Valve for Water & Chemical Application.

Technical Details :-

Manufacturing Std. : API 603
Face to Face : ANSI B16.10
End Connection : Flanged Ends to ANSI B16.5 RF 150# / 300#
Inspection & Testing Std. : API 598

Features :-

- ❖ Design Standards : API 603
- ❖ Design Configurations : Bolted Cover
Swing Type Disc
- ❖ Size Range : 1/2" – 2" (DN15 - DN300)
- ❖ Pressure Rating : ANSI 150 Up to ANSI 300



Test Pressure :-

ASA 150#	
Testing Hydraulic	
Body	425 Psig (30 Kg/Cm ²)
Test	300 Psig (21 Kg/Cm ²)

ASA 300#	
Testing Hydraulic	
Body	1100 Psig (77 Kg/Cm ²)
Test	800 Psig (56 Kg/Cm ²)

P.No	Parts	Qty
1	Body	1
2	Cover	1
3	Hinge	1
4	Seat Rings	1
5	Disc	2
6	Disc Retaining Nuts	1
7	Disc Washer	1
8	Hing Pin	1
9	Cover Gasket	Req.
10	Cover Studs	Req.

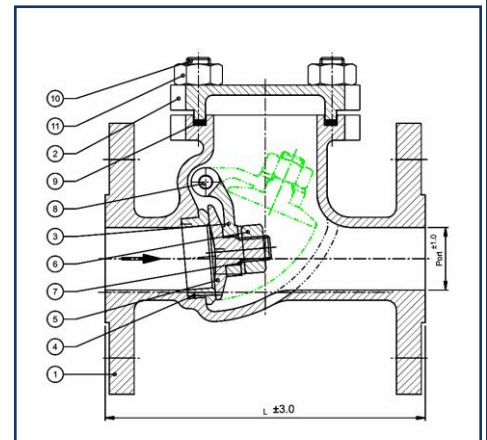

Available Options :-

Structure	End Connection	Flanged End as per ASA 150#, 300#
Material	Body	CF8, CF8M, CF3M
	Trims	SS 304, SS 316, SS 316L

Dimensions

(All Dimensions are in MM)

SIZE	15	20	25	32	40	50	65	80	100	125	150	200	250	300	
Port	16	19	25	32	38	51	64	76	102	127	152	203	254	305	
L Face to Face	(ASA-150#)	108	117	127	139.7	165.1	203.2	215.9	241.3	292.1	330.2	355.6	495.3	622.3	698.5
	(ASA-300#)	152	178	215.9	228.6	241.3	266.7	292.1	317.5	355.6	400	444.5	533.4	622.3	711.2

Lehry Instrumentation & Valves Pvt. Ltd.,

"Lehry Chambers" #78 (Old No: 51) Sembudoss Street,
P.B No.1506, Parrys, Chennai - 600 001.
Phone : 044 25226995/25225185/25226187/42163823/
42625620/42625621. Fax : 044 25231715
Email : info@lehry.com / Website : www.lehryvalves.com
Branches : Chennai, Bangalore, Hyderabad, Mumbai, Noida, Pune