

BALL TYPE CHECK VALVES S/E-B-06

PRINCIPLE OF OPERATION :-

The reinforced rubber ball is the heart of this valve. This ball in the designed path of the valve moves freely and promptly reacts to the ON & OFF of the pump. The ball moves to open position when the pump starts & allows free flow of liquid without any interference. (Fig- A) As the pump stops, the ball seats firmly against the metal seat due to its own weight & back pressure of the liquid (Fig-B) This results in DROPLESS sealing



SILENT FEATURES :-

- ❖ This valve is offered in both end-threaded design.
- ❖ New generation valve with unique and non-conventional design.
- ❖ Suitable for a very wide range of applications like slurry, sewage, paper, chemical, water supply, agriculture, muddy water, slurry, paper stock, viscous liquid and clear water.
- ❖ Robust and very simple mechanism.
- ❖ A floating reinforced rubber coated ball is used instead of hinge-pin-disc.
- ❖ Highly sensible to arrest flow with perfect sealing.
- ❖ Very low head loss
- ❖ Non clogging and self cleaning mechanism
- ❖ Maintenance free
- ❖ Power saving
- ❖ Dimensionally conforming with IS 5312
- ❖ Installation can be vertically or horizontally
- ❖ Operates silently upto 80°C
- ❖ This valve has a quality for withstanding consistent performance and longer life.

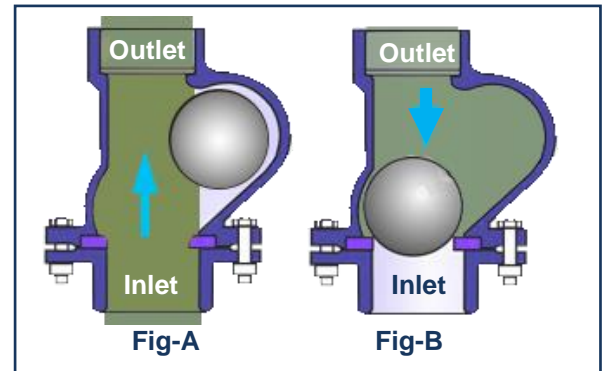

PRESSURE RATING : PN 6

MATERIAL OF CONSTRUCTION :-

Part	Description	Standard
1	Body	Cast Iron
2	Strainer	Cast Iron
3	Ball	Nitrile Rubber
4	Seal Ring	Nitrile Rubber
5	Fasteners	Carbon Steel
6	Adaptor	Cast Iron

Dimensions(All Dimensions are in mm)

A	25	40	50	65	80	100
H	100	135	165	200	244	284
W	90	125	148	190	232	275

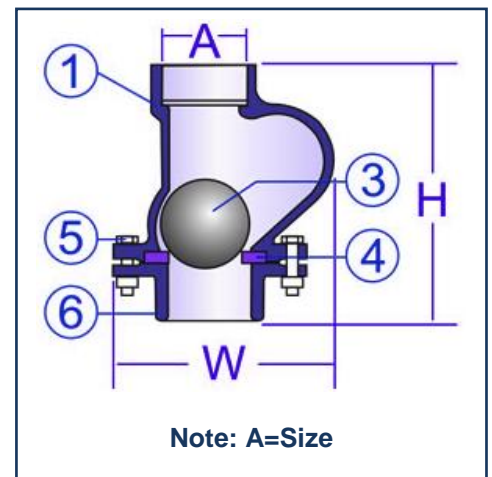

Lehry Instrumentation & Valves Pvt. Ltd.,

"Lehry Chambers" #78 (Old No: 51)Sembudoss Street,
P.B No.1506, Parrys, Chennai - 600 001.
Phone : 044 25226995/25225185/25226187/42163823/
42625620/42625621. Fax : 044 25231715
Email : info@lehry.com / Website : www.lehryvalves.com
Branches : Chennai, Bangalore, Hyderabad, Mumbai, Noida, Pune